

Muy alta eficiencia
19 SEER

ARB 2-5 (TR)

Heat Pump Inverter T1 208-230~1~50/60HZ

Unidad Roof Top Inverter para aplicaciones con ocupación media

Potencia frigorífica 10 ÷ 17 kW
Potencia térmica 11 ÷ 17 kW

- Para aplicaciones con carga media latente
- Compresor inverter scroll de alta fiabilidad adaptado a condiciones extremas.
- Sistema de Autodiagnóstico.
- Se proporciona puertos para medición de presiones externos a la unidad.
- Los paneles exteriores del gabinete prepintados superan las 500 horas de prueba de niebla salina para mayor durabilidad.
- Construido con chapa de calibre pesado galvanizada G90 conforme a ASTM-A-653.
- Tratamiento anticorrosión personalizado.
- Amplio rango de temperatura de funcionamiento

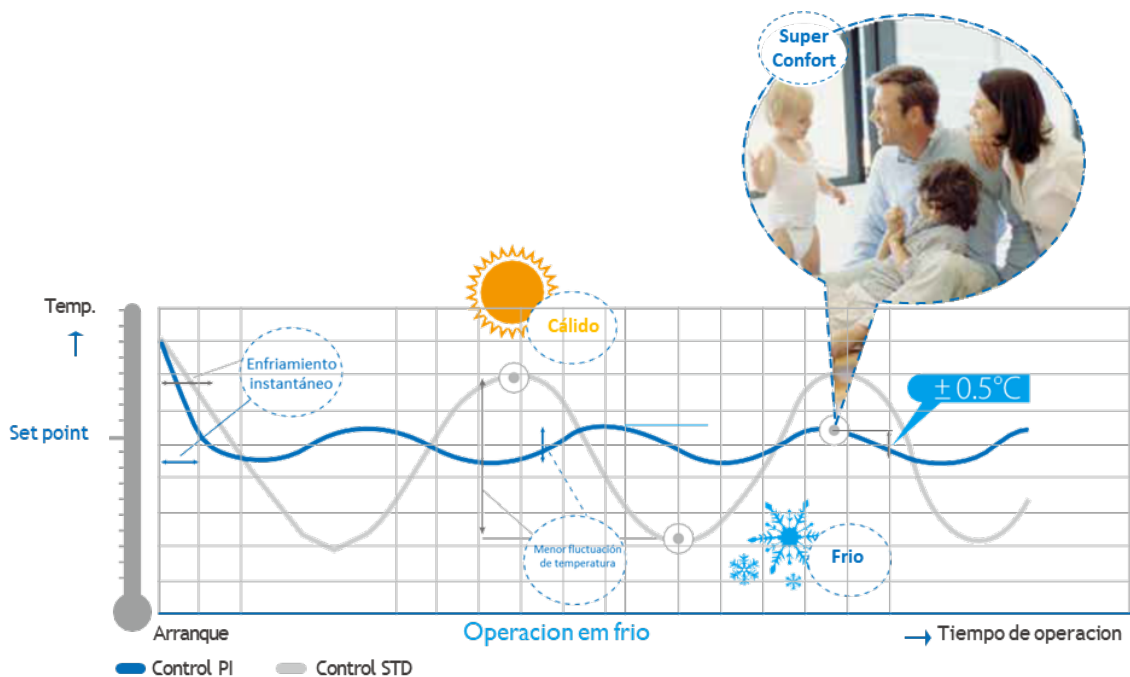
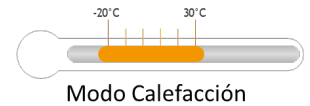
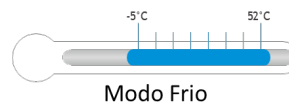



Unidad Roof Top Inverter para aplicaciones con ocupación media

Potencia frigorífica 10 ÷ 17 kW
Potencia térmica 11 ÷ 17 kW

ARB 2-5 (TR)

Heat Pump Inverter T1 208-230~1~50/60HZ

Datos generales

Roof top Series	Ambient	Power Supply	Capacity (Ton)	Aermec	COOLING			Unit dimension (WxHxD) (mm)	Gross weight (KG)	Loading quantity		
					Capacity (KW)	Power Input (KW)	EER (KW/KW)			20	40	40HQ
Heat Pump R410a	T1	208/230V 1N~ 50/60Hz	3Ton	ARB-36HWD1N1-A19	11	2,9	3,8	1,286x891x1,190	220,0	4	10	20
			5Ton	ARB-60HWD1N1-A19	17	4,5	3,8	1,310x1,140x1,306	310,0	4	9	18

Especificaciones unidades Bomba de calor

Heat Pump Inverter T1 208-230~1~50/60HZ				
Model		ARB-36HWD1N1-A19		ARB-60HWD1N1-A19
Cooling	Capacity	Btu/h	34300	57000
	SEER	Btu/hW	19	19
	EER	Btu/W	12	13
Heating	Capacity	Btu/h	36000	57000
	HSPF	W/W	9	10
	Systempower	KW	3	4
Indoor fan motor	Type		DC	DC
	Output	HP	1/12	3/4
Outdoor fan motor	Type		DC	DC
	Output	HP	1/4	1/4
	RPM		950	880
Net Dimentions (W,H,D)		mm	1286x891x1190	1310x1140x1306
Packing Dimentions (W,H,D)		mm	1330x935x1239	1329x1155x1330
ESP range		Pa	0-200	
Ambient temperature range	Cooling	°C	-5~52	
	Heating	°C	-20~30	
1. Cooling capacity test condition: Outdoor ambient temperature: 35°C (95°F), indoor temperature: 26.7°C (80°F) DB/19.4°C (67°F) WB. 2. Heating capacity test condition: Outdoor ambient temperature: 7°C (44.6°F) DB / 6°C (42.8°F) WB, indoor temperature: 20°C (68°F) DB / 15°C (59°F) WB. 3. Sound values are measured in a semi-anechoic room, at a positori 1m in front of the unit and (1 meter+Height of unit:)above the floor 4. Specilicaticms are subject to change without prior notice far product improvement 5. Nominal Tn only for reference 6. Cooling or heating capacity as per especification				

AERMEC

Muy alta eficiencia
19 SEER



Unidad Roof Top Inverter para aplicaciones con ocupación media

Potencia frigorífica 10 ÷ 17 kW
Potencia térmica 11 ÷ 17 kW

ARB 2-5 (TR)

Heat Pump Inverter T1 208-230~1~50/60HZ

Dimensions

Unit Dimensions for 36k model inch[mm]

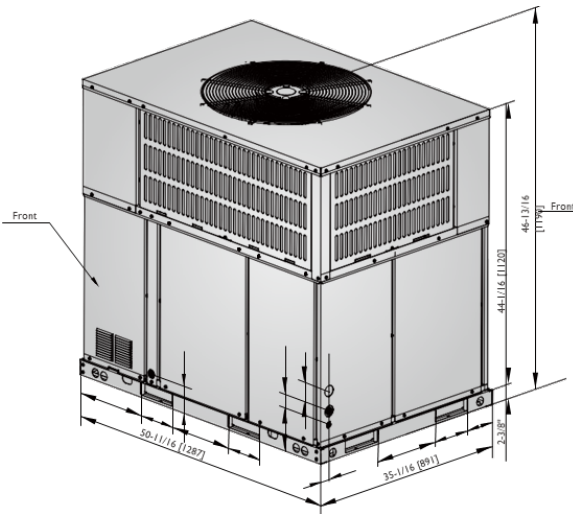

Dimensions Back and Bottom

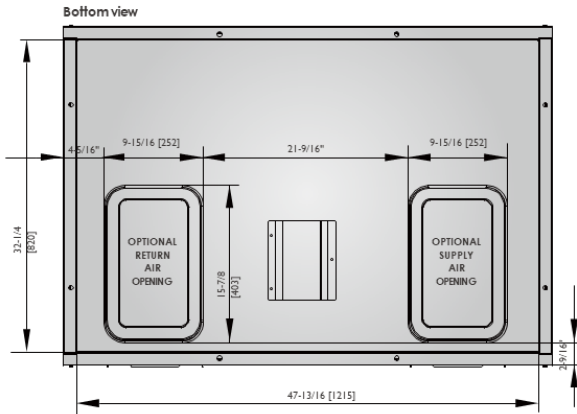

Backview

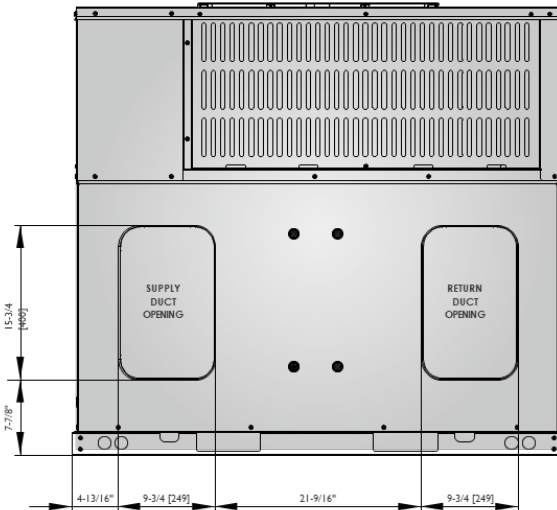

Unit Dimensions for 60k model inch[mm]

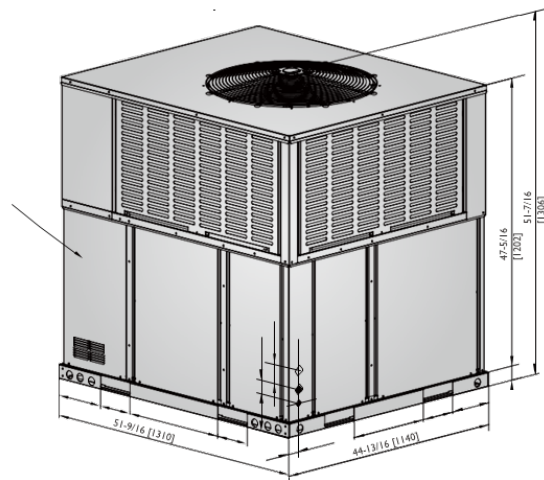

Dimensions Back and Bottom

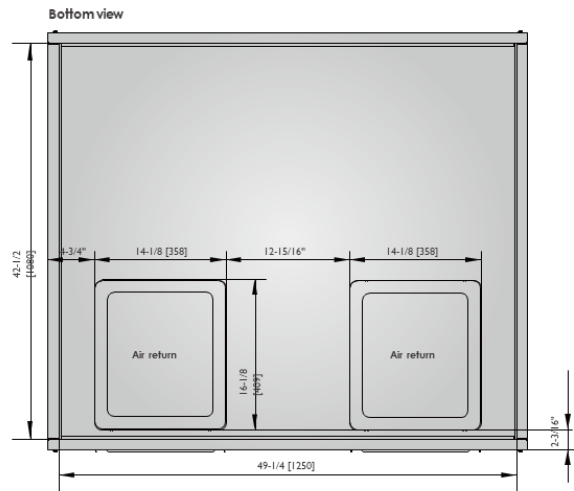

Back View

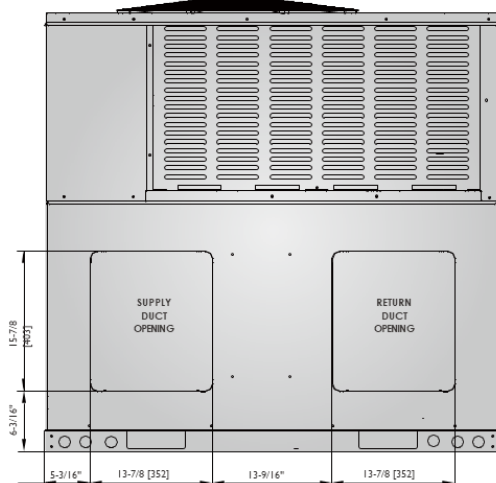



Unidad Roof Top Inverter para aplicaciones con ocupación media

Potencia frigorífica 10 ÷ 17 kW
Potencia térmica 11 ÷ 17 kW

ARB 2-5 (TR)

Heat Pump Inverter T1 208-230~1~50/60HZ

Fan performance

Model Number	Motor Speed		SCFM								
			External Static Pressure-Inches W.C.[kPa]								
			0[0]	0.1[.02]	0.2[.05]	0.3[.07]	0.4[.10]	0.5[.12]	0.6[.15]	0.7[.17]	0.8[.20]
60	Tap(1)	SCFM	1385	1300	1230	1136	1045	959	867	787	717
		Watts	164	171	180	192	204	217	232	238	249
	Tap(2)-Default Low Stage Setting	SCFM	1489	1432	1352	1279	1172	1088	1013	934	863
		Watts	1.76	1.8	1.89	1.96	2.02	2.13	2.24	2.34	2.43
	Tap(3)	SCFM	1843	1782	1711	1639	1572	1497	1409	1341	1271
		Watts	343	362	377	390	400	411	427	440	456
	Tap(4)-Default High Stage Setting	SCFM	1964	1903	1840	1786	1724	1655	1591	1488	1427
		Watts	435	450	466	479	494	507	521	535	551
	Tap(5)	SCFM	2339	2307	2247	2204	2135	2056	1922	1800	1659
		Watts	695	707	725	734	747	746	737	719	686
36	Tap(1)	SCFM	925	807	723	658	/	/	/	/	/
		Watts	114	120	126	130	/	/	/	/	/
	Tap(2)	SCFM	1103	993	911	841	776	710	596	/	/
		Watts	162	169	175	181	187	193	197	/	/
	Tap(3)	SCFM	1271	1185	1098	1031	968	819	767	709	648
		Watts	251	256	262	268	273	281	285	289	293
	Tap(4)	SCFM	1355	1310	1270	1180	1049	989	931	870	813
		Watts	296	301	307	312	318	323	327	331	336
	Tap(5)	SCFM	1522	1465	1364	1291	1231	1177	1121	1066	1017
		Watts	426	432	438	443	448	452	456	460	466

Bold outlined areas represent airflow outside of the required 300-450 cfm/ton range.

NOTES:

1. This table is only used to select the **highest blower speed**. The high stage airflow must be used as the rated airflow for the full load operation of machine.
2. The rated airflow of systems without electric heater kits requires between 300 and 450 cubic feet of air per minute (CFM). The rated airflow of systems with electric heater kits requires between 350 and 450 cubic feet of air per minute (CFM).
3. The air distribution system has the greatest effect on airflow. Therefore, the contractor should use only industry-recognized procedures.
4. Duct design and construction should be carefully done. System performance can be lowered dramatically through poor design or workmanship.
5. Air supplier ducts should be located along the perimeter of the conditioned space and properly sized. Improper location or insufficient air flow may cause drafts or noise in the ductwork.
6. Installers should balance the air distribution system to ensure proper quiet airflow to all rooms in the home. An air velocity meter or airflow hood can be used to balance and verify branch and system airflow (CFM).
7. For the IDP 3-ton, 4 Speed Fan default is Tap (1), Tap (2), Tap (3), Tap (4). For the IDP 5-ton, the default fan speeds are Tap (2) for low speed and Tap (4) for high speed.



Aermec se reserva el derecho de efectuar, en cualquier momento, todas las modificaciones que considere necesarias para mejorar el producto, modificando eventualmente los datos técnicos correspondientes.

Aermec S.p.A.
Calle Canal la Punta 8770, Bodega No 42
Top Space, Renca - Santiago
Tel. + 55 11 9 7559 4822